

# Numark®

## PPD01

24-BIT DIGITAL MIXER

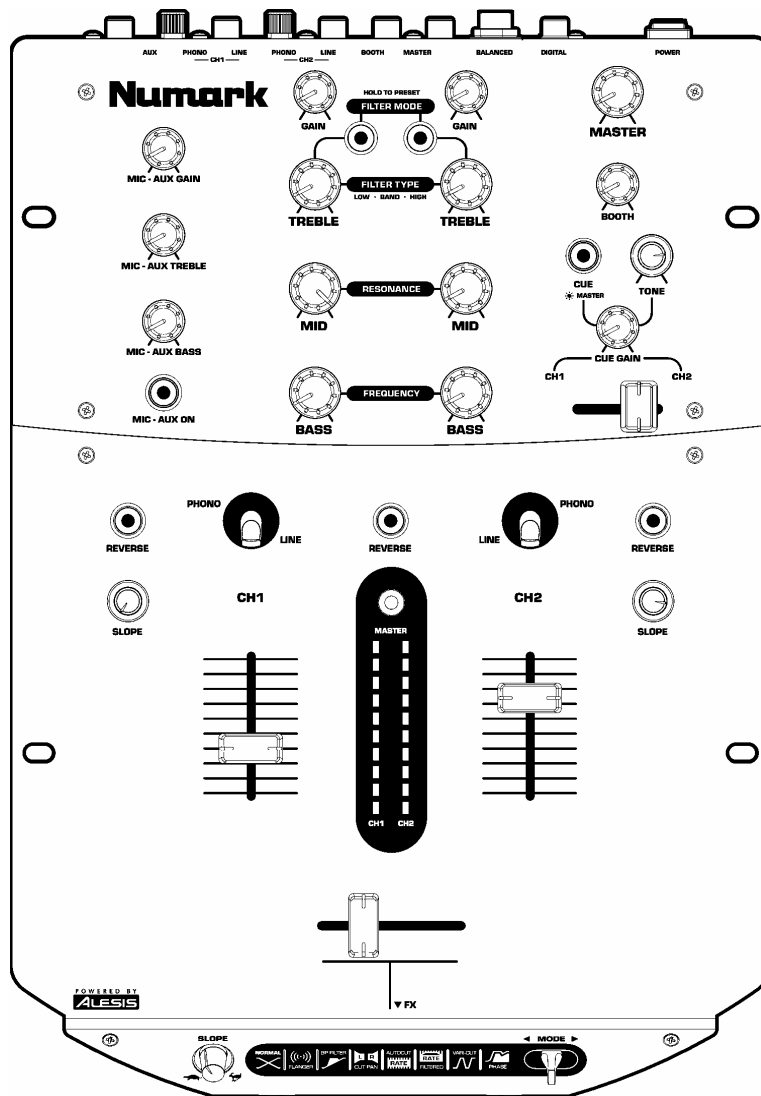

## USER'S MANUAL

## SAFETY INSTRUCTIONS

- a) **Read Instructions** - All the safety and operating instructions should be read before this product is connected and used.
- b) **Retain Instructions** - The safety and operating instructions should be kept for future reference.
- c) **Heed Warnings** - All warnings on this product and in these operating instructions should be followed.
- d) **Follow Instructions** - All operating and other instructions should be followed.
- e) **Placement** - place the unit in a clean dry location.
- f) **Water and Moisture** - This product should be kept away from direct contact with liquids. The apparatus shall not be exposed to dripping or splashing and that no objects filled with liquids, such as vases, shall be placed on the apparatus.
- g) **Temperature** - Avoid placing this product too close to any high heat sources such as radiators. Do not use this unit at temperatures below 41°F/5°C or higher than 95°F/35°C.
- h) **Ventilation** - The appliance should be situated so that its location or position does not interfere with its proper ventilation. For example, the appliance should not be situated on a bed, sofa, rug, or similar surface that may block the ventilation opening; or, placed in a built-in installation, such as bookcase or cabinet that may impede the flow of air through the ventilation openings.
- i) **Power Sources** - This product should be connected to a power supply only of the type described in these operating instructions, or as marked on the unit.
- j) **Power Cord Protection** - Power supply cords should be routed so that they are not likely to be walked upon or pinched by items placed on or against them. When removing the cord from a power outlet be sure to remove it by holding the plug attachment and not by pulling on the cord.
- k) **Object and Liquid Entry** - Take care that objects do not fall into and that liquids are not spilled into the inside of the mixer.
- l) **Cleaning** - The appliance should be cleaned only as recommended by the manufacturer. Do not use chemical solvents to clean the unit.
- m) **Non-use Periods** - The power cord of the appliance should be unplugged from the outlet when left unused for long periods of time.
- n) **Damage Requiring Service** - Only qualified personnel should service this product. If you have any questions about service please contact Numark at the number(s) shown on the back cover of this manual.
- o) **Grounding or Polarization** - Precautions should be taken so that the grounding or polarization means built into the CD player is not defeated.
- p) **Internal/External Voltage Selectors** - Internal or external voltage selector switches, if any, should only be reset and re-equipped with a proper plug for alternative voltage by a qualified service technician. Do not attempt to alter this yourself.
- q) **Carts and Stands** - The appliance should be used only with a cart or stand that is recommended by the manufacturer of the cart or stand. An appliance and cart combination should be moved with care. Quick stops, excessive force, and uneven surfaces may cause the appliance and cart combination to overturn.

### SERVICE INSTRUCTIONS

- Disconnect power cord before servicing
- Replace critical components  only with factory parts or recommended equivalents
- For AC line powered units - Before returning repaired unit to user, use an ohmmeter to measure from both AC plug blades to all exposed metallic parts. The resistance should be no more than 100,000ohms.



**CAUTION**  
**RISK OF ELECTRIC SHOCK**  
**DO NOT OPEN**



**CAUTION: TO REDUCE THE RISK OF ELECTRIC SHOCK DO NOT REMOVE ANY COVER. NO USER-SERVICEABLE PARTS INSIDE. REFER SERVICING TO QUALIFIED SERVICE PERSONNEL ONLY.**

The lightning flash with arrowhead symbol within the equilateral triangle is intended to alert the user to the presence of un-insulated "dangerous voltage" within the product's enclosure that may be of sufficient magnitude to constitute a risk of electric shock.

**The exclamation point within the equilateral triangle is intended to alert the user to the presence of important operating and maintenance (servicing) instructions in the literature accompanying this appliance.**

**CAUTION**  
**FOR USA & CANADIAN MODELS ONLY**  
**TO PREVENT ELECTRIC SHOCK DO NOT USE THIS (POLARIZED) PLUG WITH AN EXTENSION CORD, RECEPTACLE OR OTHER OUTLET UNLESS THE BLADES CAN BE FULLY INSERTED TO PREVENT BLADE EXPOSURE.**

**WARNING:** To reduce the risk of fire or electrical shock, do not expose this appliance to rain or moisture. Electrical equipment should NEVER be kept or stored in damp environments.

### NOTICE CONCERNING FCC REGULATIONS

This equipment generates and uses radio frequency energy and may cause interference to radio and television reception if you do not operate it in strict accordance with the procedures detailed in this OPERATING MANUAL. This unit complies with Class B computing device rules in accordance with the specifications in Sub-part J or Part 15 of the FCC Rules, which are designed to provide reasonable protection against such interference in a residential installation. There is no guarantee, however, that interference will not occur in a particular installation. If the unit does cause interference to any radio or television reception, try to reduce it by one or more of the following means:

- a) Reposition the other unit and/or its antennae
- b) Move this unit
- c) Move this unit and the other unit(s) further apart
- d) Plug this unit into a different AC outlet so that it is on a different circuit from the other equipment.

This note is in accordance with Section 15.838 of the FCC Rules.

This unit does not exceed the Class B limits for radio noise emission from digital apparatus set out in the radio interference regulations of the Canadian Department of Communications.

*For 220-volt use in USA, use NEMA style 220-volt plug. For other countries use proper plug for local outlet.*

**DOUBLE INSULATED - When servicing use only identical replacement parts**

**Numark- The Leader in DJ Technology**

## ***VERY IMPORTANT – MIXER CARE***

### **Please read this entire manual before connecting this unit to your system**

For optimum performance:

- All the slide faders are user replaceable items and subject to wear. Excessive force can wear out the fader quickly. This is not a warranted item.
- Never use spray cleaners on the slide controls. Residues cause excessive dirt build-up and this will void your warranty. In normal use slide controls can last for many years. If they malfunction (usually because of a dirty or dusty environment) consult a professional technician.
- Always make sure that AC power is OFF while making any connections.
- Use appropriate cables throughout your system. Do not use excessively long cables (i.e. over 50ft/14m) Be sure plugs and jacks are tightly mated. Loose connections can cause hum, noise or intermittents that could easily damage your speakers. Make the input and output connections with readily available low-capacitance stereo cables. Quality cable makes a big difference in audio fidelity and punch. See your Numark dealer or an electronics or audio specialist store if you are not sure which cables to get.
- Never attempt to make any adjustments or repairs other than those described in this manual. Take the unit to your dealer or to an authorized Numark Service Center.
- ALWAYS remember: "TURN AMPS ON LAST AND OFF FIRST". Begin with master faders or volume controls on minimum and the amplifier gain/input control(s) down. Wait 8 to 10 seconds before turning up the volume. This prevents transients which may cause severe speaker damage.
- Use restraint when operating controls. Try to move them slowly. Rapid adjustments could damage speakers due to amplifier clipping.
- Avoid amplifier "clipping" at all costs: this occurs when the red LEDs (usually on the front panel of most professional power amplifiers) start flashing. "Clipping" is when the power amplifier is distorting and working beyond it's limits. Amplifier distortion is THE major cause of speaker failure.
- To prevent fire or shock hazard, do not expose the unit to rain or moisture. Never place cans of beer, soda, glasses of water or anything wet on top of the unit!
- The headphone outputs can be set to levels which can cause damage to your ears. Use caution.

#### ***CHECK TO BE SURE***

#### ***THE FOLLOWING ITEMS ARE IN THIS BOX:***

- **MIXER**
- **OWNERS MANUAL (THIS BOOKLET)**
- **POWER SUPPLY**

# Numark® *PPD01* 24-BIT DIGITAL MIXER

**CONGRATULATIONS...**

You have just purchased a digital mixer designed specifically for the professional DJ. This unit has been designed with the latest digital technology to offer premium performance and effects. Several innovative features are included to ensure maximum results from your performance.

Once again, congratulations and thank you for making the PPD01 your choice in professional DJ Mixers.

**Features:**

- World's only 24-bit Digital 2 Channel Mixer with a S/N ratio of >102dB\*, 0.005% THD+N, full path
- World's first mixer with all Digital, Replaceable, and Interchangeable VCA Faders with slope and reverse controls.
- World's first mixer with 8 digital crossfader functions for various DJing styles.
- World's first Dual Mode tone controls on each channel  
Mode a) 3-band Digital EQ-KILLS  
Mode b) Low Pass/Band Pass/High Pass filter option with sweepable frequency and resonance (Q)
- 8-position phono/line switches.
- Look-ahead peak limiters on the master and headphone outputs to avoid clipping
- Mini-crossfader cueing with headphone tone control.
- Master Balanced, Booth, Optical and Coax Digital outputs.
- 2 Phono, 5 Line, 1 Mic Inputs.

\*A weighted

Please record the serial number of your unit as shown on the back of the chassis as well as the name of the dealer from whom you purchased the unit. Retain this information and your original purchase receipt for your records. Please return the enclosed warranty card to register your CD player with us.

MODEL: PPD01

PURCHASED FROM: \_\_\_\_\_

SERIAL NUMBER: \_\_\_\_\_

DATE OF PURCHASE: \_\_\_\_\_

## TABLE OF CONTENTS

<b>Safety Instructions</b>	2
<b>Mixer Care and Included Items</b>	3
<b>Introduction and Registration</b>	4
<b>Specifications</b>	5
<b>Description of the Features</b>	
Face Panel	6
Rear Panel	9
<b>Set-up &amp; Connections</b>	10
<b>Crossfader Features</b>	11
<b>Warranty</b>	12

### SPECIFICATIONS

#### TECHNICAL

##### INPUTS:

Line: 100k $\Omega$  input impedance  
Max Input = 4V  
Microphone: 5k $\Omega$  input impedance  
unbalanced  
80mV rms max input  
Phono: 47k $\Omega$  input impedance

##### SIGNAL TO NOISE RATIOS\* (Full Mixing Path):

Line: Better than 102 dB  
Microphone: Better than 85 dB  
Phono: Better than 85 dB  
\*A - weighted

##### OUTPUTS:

Balanced Line: 11V rms max  
Unbalanced Line: 5.5V rms max  
Headphone: 0.5 watt into 47 $\Omega$   
Distortion: 0.005% typical

##### FREQUENCY RESPONSE:

Line: 20 Hz- 20k Hz  $\pm$ 0.1 dB  
Phono: RIAA accuracy  $\pm$ 0.5 dB

#### GENERAL

POWER CONSUMPTION: 12 Watt typical  
DIMENSIONS: 10" (W) x 14.5" (H) x 3.35" (D)  
WEIGHT: 9.5 lbs, 11.2lbs with transformer

# PPD01

## FRONT PANEL FEATURES

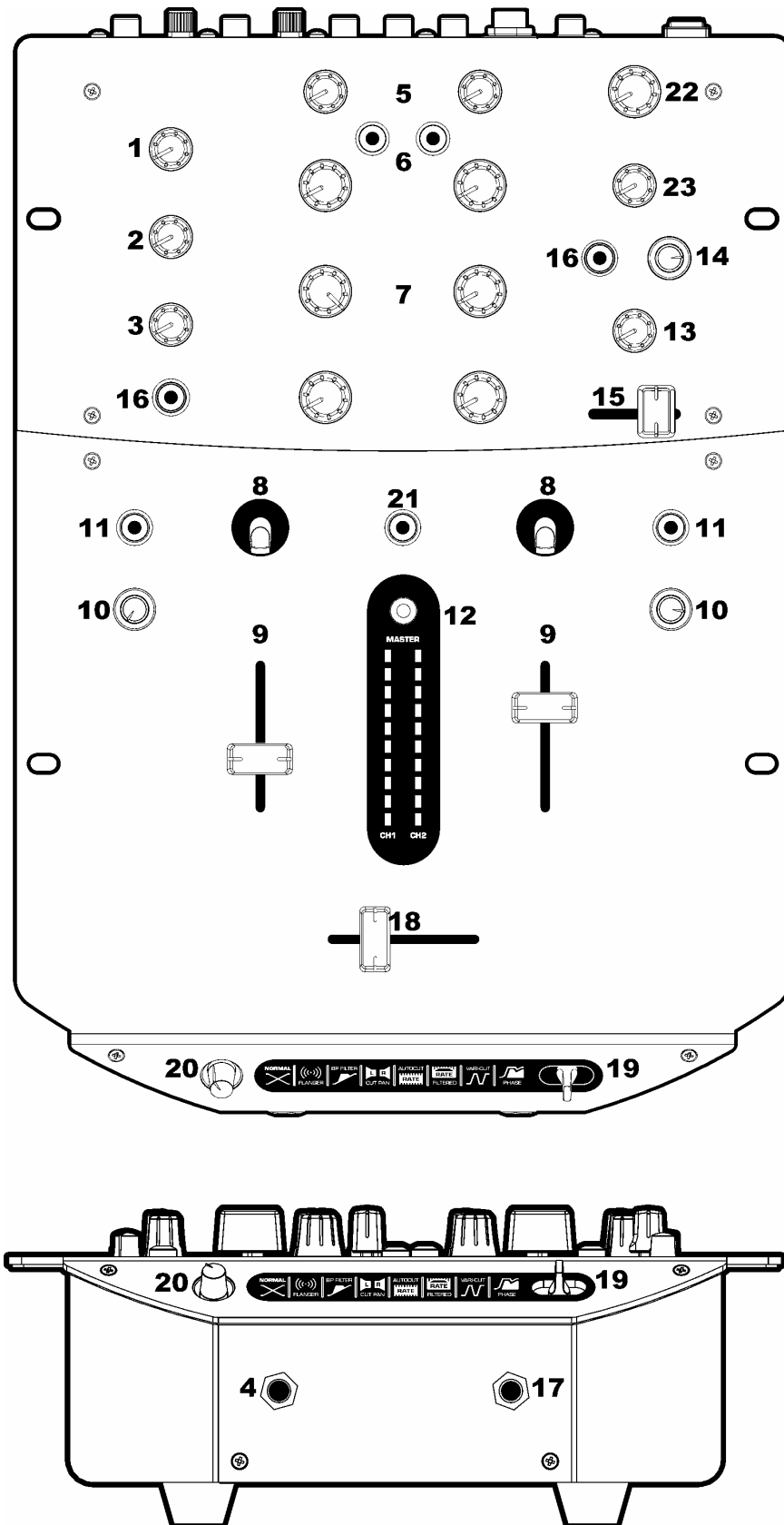

**Numark** - The Leader in DJ Technology

### Microphone - Auxiliary Input Controls

1. **"MIC – AUX GAIN" (Microphone - Auxiliary Gain):** This knob adjusts the volume of both the main microphone and auxiliary inputs. The gain should be turned completely to off when connecting and disconnecting equipment. If both inputs are used simultaneously the inputs will be mixed together.
2. **"Treble" (Microphone - Auxiliary High EQ):** This knob adjusts the high-tone input sound of the microphone.
3. **"Bass" (Microphone - Auxiliary Low EQ):** This knob adjusts the low-tone input sound of the microphone.
4. **"Microphone" (Quarter Inch Microphone Input):** One microphone can be connected to this Quarter Inch input terminal.

### Primary Mixing Channel Controls

5. **"Gain Knob" (Input Level Trim):** This rotary control adjusts the pre-fader input signal levels of the inputs. This level adjustment should be used with the pre-fader meter to match levels of both input channels.
6. **"Filter Mode Button" (Control Mode Select):** This button toggles the control knob mode between EQ and Filter. When the indicator light is on, the three knobs control a classic filter (Type, Resonance, Frequency). When the indicator light is off, the 3 tone knobs control a 3-band EQ (Bass, Mid, Treble).

**WARNING:** When switching mode the user should take care when setting and releasing levels. Excessive output can occur if levels or effects are released when set too high. This could lead to equipment or hearing damage.

*Note: If the user pushes and holds this button, the parameter of the knobs will be held constant until released. In this way the user can pre-set the knobs to a desired effect position without the change being heard until the button is released.*

7. **Control Knobs:** These knobs control the post gain and pre line fader audio signal. Their function is determined by the "Filter Mode Button" position

#### EQ Mode

**"Treble" (Input Level High EQ):** This rotary control adjusts the high-tone sound of the inputs. Turning the knob completely to the right increases the level, turning the knob completely to the left decreases the level to off. This music "KILL" control allows for unique mixing styles.

**"Middle" (Input Level Midrange EQ):** This rotary control adjusts the high-tone sound of the inputs. Turning the knob completely to the right increases the level, turning the knob completely to the left decreases the level to off. This music "KILL" control allows for unique mixing styles.

**"Bass" (Input Level Low EQ):** This rotary control adjusts the high-tone sound of the inputs. Turning the knob completely to the right increases the level, turning the knob completely to the left decreases the level to off. This music "KILL" control allows for unique mixing styles.

#### Filter mode

**"Type Knob" (Filter Select):** This rotary control continuously fades between Low-Pass, Band-Pass & High-Pass Filter.

**"Frequency Knob" (Frequency Select):** This rotary control sweeps between 60-20kHz center frequency.

**"Resonance Knob" (Intensity Control):** This rotary control controls the resonant peak at the center frequency.

8. **"Phono(AUX)/Line Switch" (Input Selector Switch):** These two-position toggles select what input source is engaged among the connected units (see "**Connection Diagram**" for details on connecting sources.) These toggles can be rotated to suit your mixing preferences by removing the top Mixer Panel and adjusting their position.
9. **"Input Level Slider" (VCA Fader):** These slide faders adjust the level for CH-1 or CH-2 respectively.
 

**Note:** This fader is user replaceable if it should ever wear out. Simply remove the facepanel and then remove the screws holding it in position. Replace the fader with a quality authorized replacement from your local Numark retailer.
10. **"Slope Knob" (Input Fader Curve Style Control):** The position of this knob determines the rate of volume level increase of the fader. When turned to the left, the fader will gradually fade in the volume as it is engaged. When it is turned all the way to the right, a very sharp fade of the volume will occur immediately when the fader is engaged.
11. **"Reverse Button" (Input Fader Reverse Control):** Activation of this switch can reverse the fader direction.

## Cueing / Monitor Controls

12. **"Program/PFL Level Meter and Button"**: Press to alternate display modes.
  - a) When **PROGRAM** is indicated, this meter displays the stereo output levels of your mixed signal.
  - b) When **CH1 CH2** is indicated the meter shows the peak, **"PFL"**, Pre Fader levels of channels 1 and 2. You can use the channel "Gain" and "EQ" controls to match the levels of input signals while cueing
13. **"Cue Gain Knob" (Headphone Level)**: This rotary control adjusts the levels of the headphones connected to the front panel input.
14. **"Cue Tone Knob" (Headphone Tone Control)**: This rotary knob adjusts the tone of the headphone output. The knob can be raised and lowered to hide away by pressing it down.
15. **"Channel Cue Slider"**: Channels 1 and 2 can be previewed using this mini-crossfader. Sliding this to the left plays the left channel-1 and sliding to the right plays the right channel-2.
16. **"Cue Button" (MIC and MASTER Cue Buttons)**: When pressed, the CUE button illuminates green indicating that the source is being cued to the headphones. When you press Mic PFL it adds it to the cue mix. When Master Cue is pressed only the master output is heard.
17. **"Headphone Jack" (Quarter Inch Output Terminal)**: Your headphones can be connected to this ¼" terminals. The Volume should always be set at its lowest setting while connecting and disconnecting headphones to prevent damage to headphones and/or your hearing.

## Crossfader Controls

18. **"Crossfader Slider" (Digital VCA Crossfader)**: This slide fader blends audio between CH-1 and CH-2. Its action can be modified with the "Mode", "Slope", and "Direction" controls. This digital mixer uses digital VCA technology to accurately determine slider position. Both the VCA and Digital technologies combined allow for some very powerful effects.

**Note:** This fader is user replaceable if it should ever wear out. Simply remove the facepanel and then remove the screws holding it in position. Replace the fader with a quality authorized replacement from your local Numark retailer.
19. **"MODE and MODE Display" (Crossfader Function Control and Display)**: This toggle switch changes crossfader modes be left-right movement. The current mode is indicated in the mode display under the crossfader. These modes are described in detail in the section entitled **"CROSSFADER MODES"**.
20. **"Contour Knob" (Crossfader Rate/Slope Control)**: The position of this switch determines how quickly or intensely the crossfader will act depending upon mode setting.
21. **"Direction Button" (Crossfader Reverse Control)**: Activation of this switch reverses the assignment of CH-1 and CH-2 on the crossfader.

## Output Controls

22. **"Master Knob" (Main Output Level Control)**: This rotary control adjusts the main output volume.
23. **"Booth Knob" (Master/Split Style Headphone Cueing Switch)**: This rotary control adjusts the auxiliary (AKA booth) output volume.



## REAR PANEL FEATURES

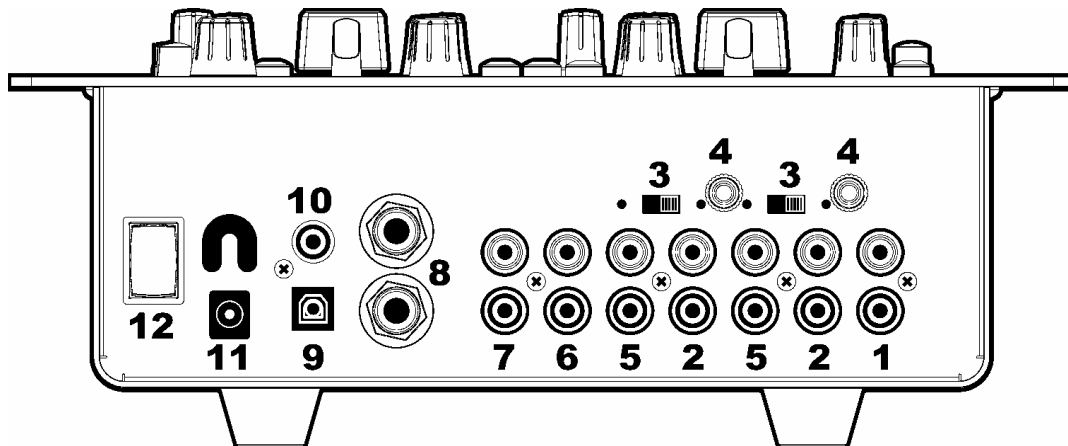

**Note:** It is recommended that the mixer be turned off before connecting and disconnecting any sources to the inputs of the mixer.

1. **"AUX-SESSION INPUT" (Auxiliary Input):** The line level input is used to connect the output from an external mixers or additional CD players and other line level devices such as samplers, tape decks, keyboards, and line output turntables. This input is mixed with any connected microphone.
2. **"Phono/AUX Inputs" (Turntable Input Connection):** The Phono input is used for connecting your turntables or other devices. Input source is determined by the PHONO/LINE switch on the rear panel.
3. **"Phono/Line source switch":** This switch activates and deactivates the sensitive RIAA phono preamplifiers. **Only turntables with phono level output should be assigned when the switch is in the phono position.** Some turntables offer line level output. To use these turntables and other line devices like CD players, switch the input to Line.
4. **"GND" (Grounding Lug):** This screw connector should be used to secure any devices connected to the mixer that need to be grounded. Many turntables that are connected to the mixer will need to have a ground wire that is designed to connect to the mixer's chassis to eliminate hum and excessive noise.
5. **"Line Inputs" (CD player, Tape Deck, Sampler Input Connection):** The line level input is used to connect CD players and other line level devices such as samplers, tape decks, keyboards, and line output turntables.
6. **"Booth Output" (Auxiliary Stereo Unbalanced Output):** This RCA output is for connecting a secondary external monitoring device such as a booth monitor or second stereo output. The level of the booth output signal will increase as the "Booth" volume control is increased.
7. **"Master Unbalanced Output" (Main Stereo RCA Output):** This RCA output is for connecting an external monitoring device such as a PA system, powered monitors or a home stereo. The level of the master stereo output signal increases as the "master" volume control is increased.
8. **"Master Balance Output" (Balanced Quarter Inch Stereo Output):** These 1/4" outputs are for sending a balanced level signal to a PA system or recording device. The level of the balanced output signal will also increase with the "master" volume control. These outputs are durable, offer a better output signal, and are well suited for long cable runs.
9. **"Digital Output" (Optical):** 48kHz, 24-bit S/PDIF output. The format is type 2, form 1, also known as S/PDIF (Sony/Phillips Digital Interface Format). This output can be connected to compatible devices such as CD Burners, Hard Drive recorders, or other digital mixers. Higher audio fidelity is maintained from these outputs.
10. **"Digital Output" (Coax):** 48kHz, 24-bit S/PDIF output. The format is type 2, form 1, also known as S/PDIF (Sony/Phillips Digital Interface Format). This output can be connected to compatible devices such as CD Burners, Hard Drive recorders, or other digital mixers.
11. **AC In:** This mixer is designed to work with the power supply assembly that comes with the unit. While the power is switched off, plug the power supply into the mixer first, then plug it into the outlet.
12. **Power Switch:** Use this switch to turn on the mixer after all input devices are already connected to prevent damage to your equipment. Turn the mixer on before you turn on amplifiers and turn off amplifiers before you turn off the mixer.

# PPD01

## QUICK SETUP DIAGRAM

1. Study this setup diagram.
2. Make sure all faders are at "zero" and all devices are off.
3. Connect all stereo input sources, your microphone, and monitor headphones
4. Connect the stereo outputs to the power amplifier(s) and/or audio sources.
5. Plug your mixer and other devices into AC power.
6. Switch everything on in the following order.
  - audio input sources (i.e. turntables or CD players)
  - your mixer
  - last, any amplifiers
7. When turning off, always reverse this operation by,
  - turning off amplifiers
  - your mixer
  - last, any input devices

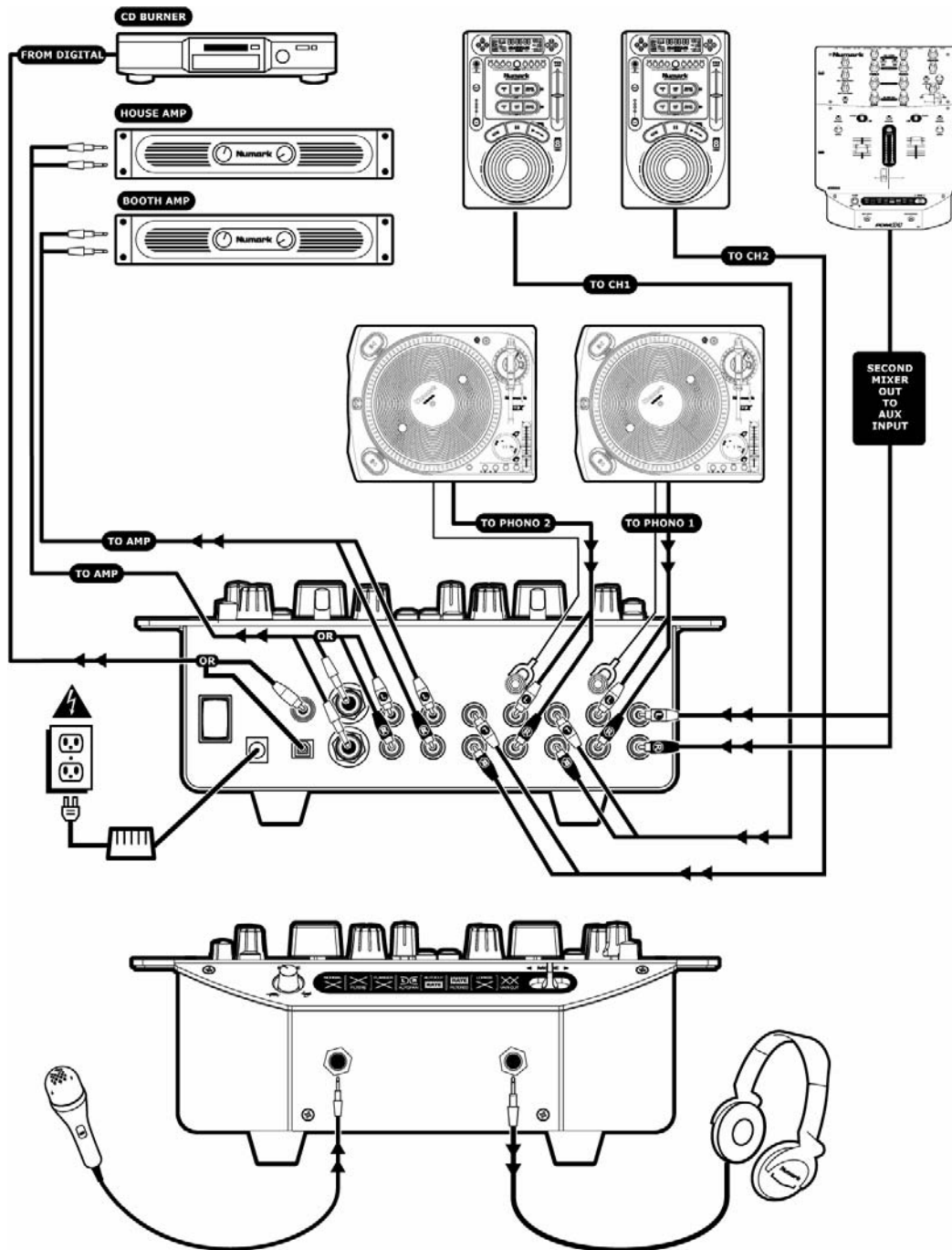

**Numark- The Leader in DJ Technology**

## CROSSFADER MODES

This section describes the actions of your digital crossfader, depending upon mode settings.

### NORMAL



**Normal Fade:** The contour knob controls the slope of crossfader. As a slope control, when the contour is rotated to the left, the Crossfader will gradually fade from one channel to the other. When rotated to the right, a very sharp fade between channels will occur immediately when the fader is moved.



### FLANGER

**Velocity Sensitive Flanger:** The velocity of the crossfader controls the amount of flanger applied to the output. The contour knob controls the rate of the flanger.

### BP FILTER



**Velocity Sensitive Band Pass Filter:** The velocity of the crossfader controls the mix and frequency of a Band-Pass filter applied to the output. The contour knob controls the slope of crossfader.



### CUT PAN

**Autopan:** The current channel will be mixed in on either left or right only when the crossfader is initially moved inwards. As the crossfader is moved to the center, the pan for the other channel is re-balanced to the center. Every time the crossfader is brought inwards from an endpoint, the mix will toggle between left and right. The contour knob controls the slope of crossfader.

### AUTOCUT



**Auto-Cut:** This crossfader creates a gating effect when the user moves the crossfader inwards from an endpoint. The crossfader mode indicator will flash at the gating rate, which is controlled by the contour knob. When the crossfader is moved towards the middle, it passes a threshold which will stop the gating effect. The gating will not start again until the user returns to an endpoint and moves inwards again.



### FILTERED

**Auto-Cut with Low Pass filter:** This works similarly to "Autocut" except a LP filter is also applied to the channel. The LP filter sweeps from 120 to 20kHz(full spectrum) as the crossfader is moved towards the middle.



### PHASE

**Dual Phase Shifter:** The audio will be phase shifted when the fader is moved inwards from an endpoint. The phase shifting will mix to dry as the xfader is moved to center. The contour knob controls the slope of crossfader.

### VARI-CUT



**Vari-Cut:** Using the contour knob, the user can position a brief audio cut in the crossfader. At one extreme of the contour knob, both sides of the crossfader have a centered cut, making the master audio output completely cut out in the center. At the other extreme, the cuts move towards their respective endpoints. Different cut points will allow the user to double their "crabbing" or "chirping" rate, or find a comfortable offset cut-in point.

# **Numark<sup>®</sup>**

## ***Professional Disc Jockey Products***

### **LIMITED PRODUCT WARRANTY**

1. What is covered and for how long? NUMARK INDUSTRIES LCC ("NUMARK") warrants to the original purchaser that NUMARK'S DJ Mixers, Amplifiers, CD players, turntables, preamplifiers, beatkeepers, equalizers, microphones, headphones, and all other accessories are free from defects in material and workmanship under normal use and service for the period commencing upon the date of purchase from an authorized NUMARK dealer and continuing for the following period of time after that date for (1) Year.
2. What is not covered? This Limited Warranty is conditioned upon proper use of the product by the purchaser. This Limited Warranty does not cover: (a) defects or damage resulting from accident, misuse, abuse, neglect, unusual physical or electrical stress, modification of any part of the product, or cosmetic damage; (b) equipment that has the serial number removed or made illegible; (c) all plastic surfaces and other externally exposed parts that are scratched or damaged due to normal use; (d) defects or damage from improper testing, operation, maintenance, installation, adjustment, or service of the mixers; (e) crossfaders.
3. What are NUMARK'S obligations? During the applicable warranty period, NUMARK will repair or replace, at NUMARK'S sole discretion, without charge to the purchaser, any defective component part of the mixer. To obtain service under this Limited Warranty, purchaser must first contact NUMARK and obtain a return authorization number ("RA#"). Purchaser must then return the mixer to NUMARK in an adequate container for shipping, accompanied by purchaser's sales receipt or comparable proof of sale showing the date of purchase, the serial number of the product, and the seller's name and address. To obtain an RA# and assistance on where to return the mixer, contact NUMARK customer service at 401-295 9000. Upon receipt, NUMARK will repair or replace the defective products. NUMARK may, at NUMARK'S sole discretion, use rebuilt, reconditioned, or new parts or components when repairing any product or replace a product with a rebuilt, reconditioned or new product. Repaired mixers will be warranted for a period equal to the remainder of the original Limited Warranty on the original mixer or for (90) days, whichever is longer. All replaced parts, components, boards and equipment become the property of NUMARK. If NUMARK determines that any mixer is not covered by this Limited Warranty, purchaser must pay all parts, shipping, and labor charges for the repair or return of such mixer.
4. What are the limits on NUMARK'S liabilities? THE WARRANTIES GIVEN IN THIS LIMITED WARRANTY, TOGETHER WITH ANY IMPLIED WARRANTIES COVERING NUMARK MIXERS, INCLUDING WITHOUT LIMITATION ANY WARRANTIES OF MERCHANTABILITY OR FITNESS FOR A PARTICULAR PURPOSE, ARE LIMITED TO THE DURATION OF THIS LIMITED WARRANTY. EXCEPT TO THE EXTENT PROHIBITED BY APPLICABLE LAW, NUMARK SHALL NOT BE LIABLE FOR ANY SPECIAL, INCIDENTAL, CONSEQUENTIAL, INDIRECT OR SIMILAR DAMAGES, LOSS OF PROFITS, DAMAGES TO PURCHASER'S PROPERTY, OR INJURY TO PURCHASER OR OTHERS ARISING OUT OF THE USE, MISUSE OR INABILITY TO USE ANY NUMARK MIXER, BREACH OF WARRANTY, OR NEGLIGENCE, INCLUDING BUT NOT LIMITED TO NUMARK'S OWN NEGLIGENCE, EVEN IF NUMARK OR ITS AGENT HAS BEEN ADVISED OF SUCH DAMAGES, OR FOR ANY CLAIM BROUGHT AGAINST PURCHASER BY ANY OTHER PARTY. THIS LIMITED WARRANTY IS THE COMPLETE WARRANTY FOR NUMARK'S MIXERS, AND IS GIVEN IN LIEU OF ALL OTHER EXPRESS WARRANTIES. THIS LIMITED WARRANTY SHALL NOT EXTEND TO ANYONE OTHER THAN THE ORIGINAL PURCHASER OF THIS PRODUCT AND STATES PURCHASER'S EXCLUSIVE REMEDY. IF ANY PORTION OF THIS LIMITED WARRANTY IS ILLEGAL OR UNENFORCEABLE BY REASON OF ANY LAW, SUCH PARTIAL ILLEGALITY OR UNENFORCEABILITY SHALL NOT AFFECT THE ENFORCEABILITY OF THE REMAINDER OF THIS LIMITED WARRANTY WHICH PURCHASER ACKNOWLEDGES IS AND WILL ALWAYS BE CONSTRUED TO BE LIMITED BY ITS TERMS OR AS LIMITED AS THE LAW PERMITS. This Limited Warranty allocates risk of product failure between purchaser and NUMARK, and NUMARK'S product pricing reflects this allocation of risk and the limitations of liability contained in this Limited Warranty. The agents, employees, distributors, and dealers of NUMARK are not authorized to make modifications to this Limited Warranty, or make additional warranties binding on NUMARK. Accordingly, additional statements such as dealer advertising or presentation, whether oral or written, do not constitute warranties by NUMARK and should not be relied upon.
5. How does state law apply to this warranty? SOME STATES DO NOT ALLOW THE EXCLUSION OR LIMITATIONS OF INCIDENTAL OR CONSEQUENTIAL DAMAGES OR HOW LONG AN IMPLIED WARRANTY LASTS, SO THE ABOVE LIMITATIONS OR EXCLUSIONS MAY NOT APPLY TO PURCHASER.
6. This Limited Warranty gives you specific legal rights. You may also have other rights, which vary from one jurisdiction to another.

### **RETURN INFORMATION**

- A Return Authorization number must be obtained from Numark through the address or phone numbers below.
- A copy of the original sales receipt must also be included for the equipment to be repaired under warranty.
- The faulty equipment must be packed in its original packaging.
- One additional outer layer of packaging must be included to ensure product safety. Failures to do so may inadequately protect the equipment in transit and, therefore, jeopardize the customer's warranty.
- Numark will not accept COD shipments and no call tags will be issued for merchandise return.
- Numark will not return repaired merchandise to customers by priority service, unless by written request at the customer's cost. Requests must be submitted in writing with merchandise returned.
- The defective Numark equipment should be sent, FREIGHT PREPAID with Return Authorization number clearly printed on the outer packaging and original sales receipt enclosed to:

**Numark** INDUSTRIES  
Attention: Service Department  
11 Helmsman Avenue  
North Kingstown, RI 02852 USA

Phone: +1 (401) 295-9000  
Fax: +1 (401) 295-5200  
Web: [www.numark.com](http://www.numark.com)