

Numark®

Matrix 2 Operating Instructions

Thank you for buying this Numark product.
Please read these operating instructions so you will know how to operate this equipment properly.
After you have finished reading these instructions, keep them for future reference.

WARNING: TO PREVENT FIRE OR SHOCK HAZARD, DO NOT EXPOSE THIS APPLIANCE TO RAIN OR MOISTURE.

CAUTION:

This product satisfies FCC regulations when shielded cables and connectors are used to connect the unit to other equipment. To prevent electromagnetic interference with electric appliances such as radios and televisions, use shielded cables and connectors for connections.

IMPORTANT NOTICE:

RECORD THE MODEL NUMBER AND SERIAL NUMBER OF THIS EQUIPMENT BELOW.

MODEL NO: Matrix-2
SERIAL NO: _____

SAFETY PRECAUTIONS

READ INSTRUCTIONS

All the safety and operating instructions should be read before the product is operated.

RETAIN INSTRUCTIONS

The safety and operating instructions should be retained for future reference.

HEED WARNINGS

All warnings on the product and in the operating instructions should be adhered to.

FOLLOW INSTRUCTIONS

All operating and use instructions should be followed.

CLEANING

Unplug this product from the wall outlet before cleaning. The product should be cleaned only with a polishing cloth or a soft dry cloth. Never clean with furniture wax, benzene, insecticides or other volatile liquids since they may corrode the cabinet.

ATTACHMENTS

Do not use attachments not recommended by the product manufacturer as they may cause hazards.

WATER AND MOISTURE

Do not use this product near water - for example, near a bathtub, washbowl, kitchen sink, or laundry tub; in a wet basement; or near a swimming pool; and the like.

ACCESSORIES

Do not place this product on an unstable cart, stand, tripod, bracket, or table. The product may fall, causing serious injury to a child or adult and serious damage to the product. Use only with a cart, stand, tripod, bracket, or table recommended by the manufacturer, or sold with the product. Any mounting of the product should follow the manufacturer's instructions, and should use a mounting accessory recommended by the manufacturer.

CART

A product and cart combination should be moved with care. Quick stops, excessive force, and uneven surfaces may cause the product and cart combination to overturn.

POWER SOURCES

This product should be operated only from the type of power source indicated on the marking label. If you are not sure of the type of power supply to your home, consult your product dealer or local power company.

LOCATION

The appliance should be installed in a stable location.

NONUSE PERIODS

The power cord of the appliance should be unplugged from the outlet when left unused for a long period.

GROUNDING OR POLARIZATION

If this product is equipped with a polarized alternating current line plug (a plug having one blade wider than the other), it will fit into the outlet only one way. This is a safety feature. If you are unable to insert the plug fully into the outlet, try reversing the plug. If the plug should still fail to fit, contact your electrician to replace your obsolete outlet. Do not defeat the safety purpose of the polarized plug. If this product is equipped with a three-wire grounding type plug, a plug having a third (grounding) pin, it will only fit into a grounding type power outlet. This is a safety feature. If you are unable to insert the plug into the outlet, contact your electrician to replace your obsolete outlet. Do not defeat the safety purpose of the grounding type plug.

POWER-CORD PROTECTION

Power-supply cords should be routed so that they are not likely to be walked on or pinched by items placed upon or against them, paying particular attention to cords at plugs, convenience receptacles, and the point where they exit from the product.

OUTDOORS ANTENNA GROUNDING

If an outside antenna or cable system is connected to the product, be sure the antenna or cable system is grounded to provide some protection against voltage surges and built-up static charges. Article 810 of the National Electrical Code, ANSI/NFPA 70, provides information with regard to proper grounding of the mast and supporting structure, grounding of the lead-in wire to an antenna discharge unit, size of grounding conductors, location of antenna-discharge unit, connection to grounding electrodes, and requirements for the grounding electrode.

LIGHTNING

For added protection for this product during a lightning storm, or when it is left unattended and unused for long periods, unplug it from the wall outlet and disconnect the antenna or cable system. This will prevent damage to the product due to lightning and power-line surges.

POWER LINES

An outside antenna system should not be located in the vicinity of overhead power lines or other electric light or power circuits, or where it can fall into such power lines or circuits. When installing an outside antenna system, extreme care should be taken to keep from touching such power lines or circuits, as contact with them might be fatal.

OVERLOADING

Do not overload wall outlets, extension cords, or integral convenience receptacles as this can result in a risk of fire or electric shock.

OBJECT AND LIQUID ENTRY - Never push objects of any kind into this product through openings as they may touch dangerous voltage points or short-out parts that could result in a fire or electric shock. Never spill liquid of any kind on the product.

SERVICING

Do not attempt to service this product yourself as opening or removing covers may expose you to dangerous voltage or other hazards. Refer all servicing to qualified service personnel.

DAMAGE REQUIRING SERVICE

Unplug this product from the wall outlet and refer servicing to qualified service personnel under the following conditions:
When the power-supply cord or plug is damaged.
If liquid has been spilled, or objects have fallen into the product.
If the product has been exposed to rain or water.
If the product does not operate normally by following the operating instructions. Adjust only those controls that are covered by the operating instructions as an improper adjustment of other controls may result in damage and will often require extensive work by a qualified technician to restore the product to its normal operation.
If the product has been dropped or damaged in any way.
When the product exhibits a distinct change in performance - this indicates a need for service.

REPLACEMENT PARTS

When replacement parts are required, be sure the service technician has used replacement parts specified by the manufacturer or have the same characteristics as the original part. Unauthorized substitutions may result in fire, electric shock, or other hazards.

SAFETY CHECK

Upon completion of any service or repairs to this product, ask the service technician to perform safety checks to determine that the product is in proper operating condition.

HEAT

The product should be situated away from heat sources such as radiators, heat registers, stoves, or other products (including amplifiers) that produce heat.

HANDLING AND CARE

Location

Install the mixer in a well-ventilated location where it will not be exposed to high temperatures or humidity. Do not install the mixer in a location that is exposed to direct rays of the sun, or near stoves or radiators. Excessive heat can adversely affect the cabinet and internal components. Installation of the unit in a damp or dusty environment may also result in a malfunction or accident. (Avoid installation near cookers etc., where the unit may be exposed to oily smoke, steam or heat.)

Cleaning the Unit

Use a polishing cloth to wipe off dust and dirt.

Do not spray any cleaners or lubricants into the mixer faders. This may damage the mixer and will void the product warranty.

When the surfaces are very dirty, wipe with a soft cloth dipped in some neutral cleanser diluted five or six times with water and wrung out well, then wipe again with a dry clothe.

Do not use furniture wax or cleaners.

Never use thinners, benzene, insecticide sprays or other chemicals on or near this unit, since these may damage the surface and finishes.

Condensation

When this unit is brought into a warm room from previously cold surroundings or when the room temperature rises sharply, condensation may form inside, and the unit may not be able to attain its full performance. In cases like this, allow the unit to stand for about an hour or raise the room temperature gradually.

SETUP DIAGRAM

Power the mixer before powering the amplifier.
Turn off the amplifier before turning off the mixer.

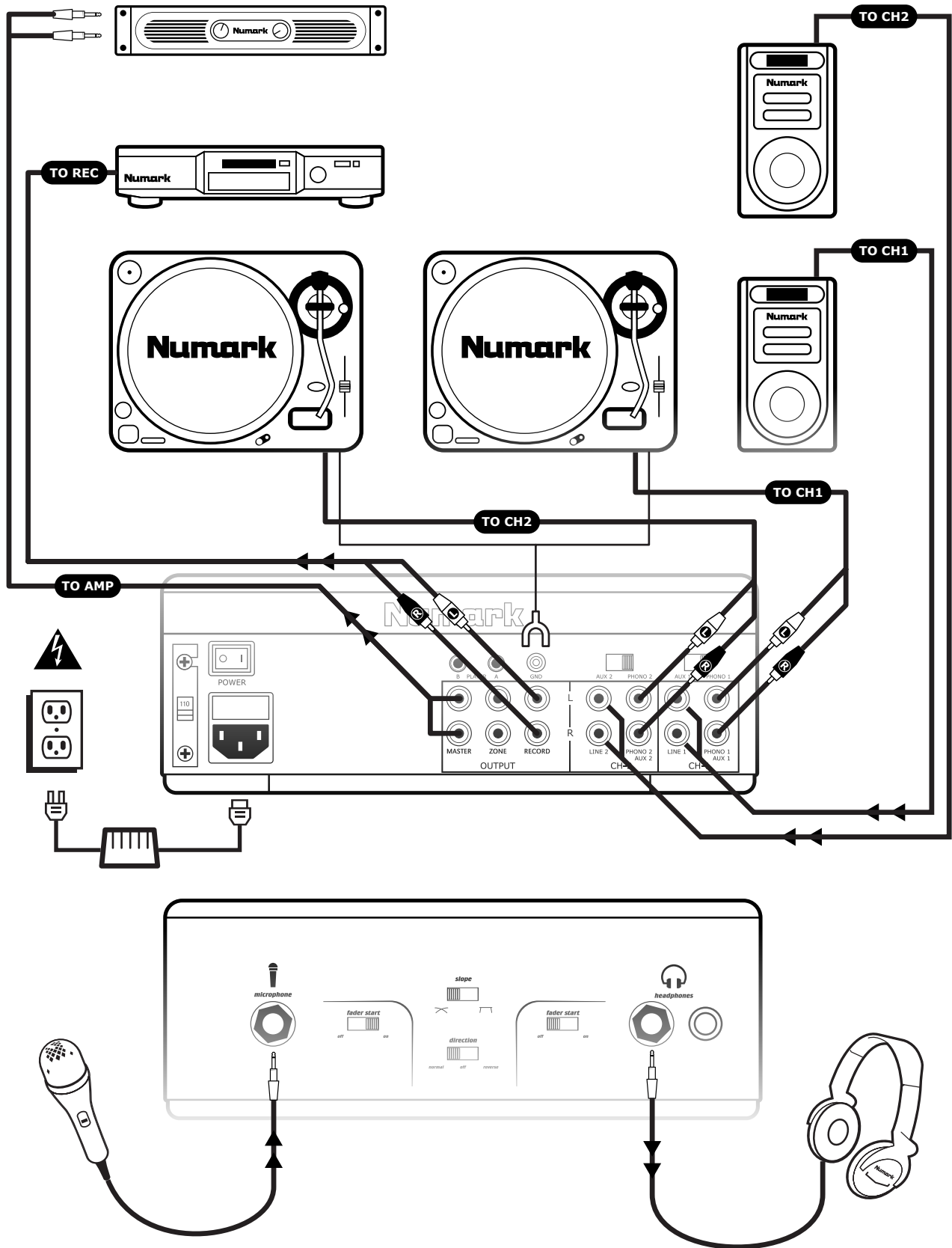

CAUTION!

TO PREVENT THE RISK OF ELECTRIC SHOCK, DO NOT REMOVE COVER (OR BACK). NO USER-SERVICEABLE PARTS INSIDE. REFER SERVICING TO QUALIFIED SERVICE PERSONNEL.



IMPORTANT

The lightning flash with arrowhead symbol, within an equilateral triangle, is intended to alert the user to the presence of un-insulated "dangerous voltage" within the product's enclosure that may be of sufficient magnitude to constitute a risk of electric shock to persons.



NOTICE

The exclamation point within an equilateral triangle is intended to alert the user to the presence of important operating and maintenance (servicing) instructions in the literature accompanying the appliance.

TABLE OF CONTENTS

Safety Precautions	1
Handling and Care	3
Setup Diagram	4
Controls	
1. Microphone Controls	5
2. Mixing Controls for CH 1 and CH 2	7
3. Meters and Lighting	9
4. Cueing Controls	9
5. Master Output Controls	11
6. Crossfader Controls	11
7. Special Crossfader Related Controls	13
8. Inputs and Outputs	15
9. Customizing and Servicing Your Mixer	17
Specifications	19
Limited Product Warranty	20
Return Information	21

CONTROLS

1. Microphone Controls

"Mic" (Microphone Trim)

This knob adjusts the volume of the main microphone. When turned all the way to the left, the volume is off. When turned to the right, the volume is at a maximum. The Microphone Trim should be turned completely to the left when connecting and disconnecting a microphone from the Quarter-Inch "Microphone" Input on the front panel of the mixer.

"Middle" (Microphone Midrange EQ)

This knob adjusts the low-tone input sound of the microphone. The center position for this control is flat. Turning this knob to the right increases the low-tone input sound of the microphone. Turning this knob to the left decreases the low-tone input sound of the microphone.

"Treble" (Microphone High EQ)

This knob adjusts the high-tone input sound of the microphone. The center position for this control is flat. Turning this knob to the right increases the high-tone input sound of the microphone. Turning this knob to the left decreases the high-tone input sound of the microphone.

"Bass" (Microphone Low EQ)

This knob adjusts the low-tone input sound of the microphone. The center position for this control is flat. Turning this knob to the right increases the low-tone input sound of the microphone. Turning this knob to the left decreases the low-tone input sound of the microphone.

"Microphone" (Quarter Inch Microphone Input)

One microphone can be connected to this Quarter Inch output terminal. The Microphone Trim should always be at its lowest setting while connecting and disconnecting a microphone to prevent damage to the mixer and/or your audience.

"PFL" (Microphone Pre Fade Level Cueing)

See Section 4 "Cueing Controls."

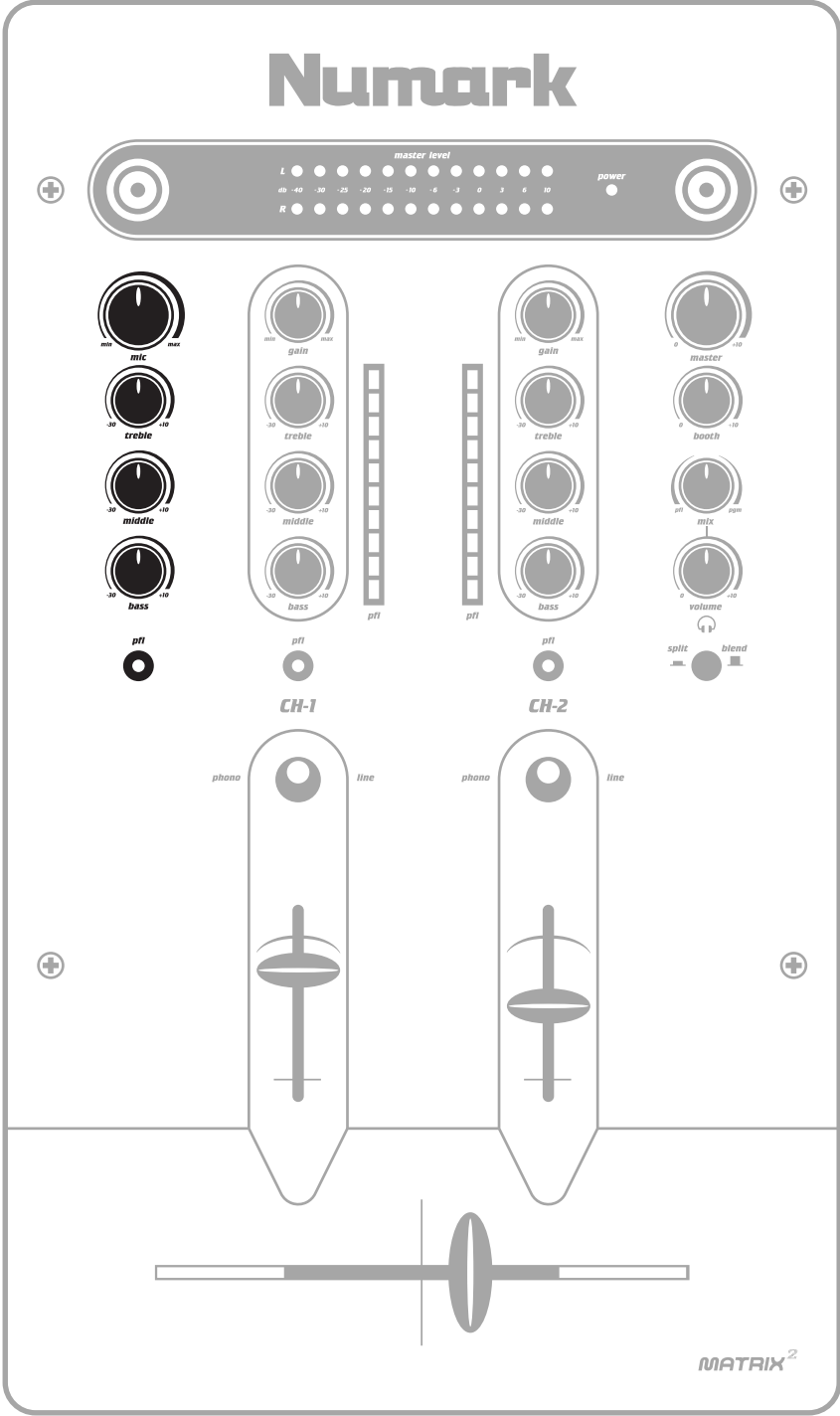

SECTION 1

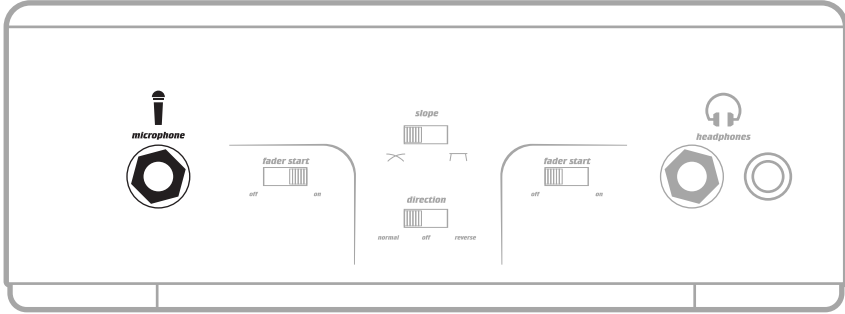

CONTROLS

2. Primary Mixing Input Controls for CH-1 and CH-2

"Gain" (Input Level Trim)

This rotary control adjusts the input signal levels of the inputs. Turning the knob completely to the right (clockwise) increases the level. Turning the knob completely to the left (counter clockwise) decreases the level.

"Treble" (Input Level High EQ)

This rotary control adjusts the high-tone sound of the inputs. Turning the knob completely to the right increases the level (to +10dB at 15kHz.) Turning the knob completely to the left decreases the level (to -28dB at 15kHz.)

"Middle" (Input Level Midrange EQ)

This rotary control adjusts the mid-tone sound of the inputs. Turning the knob completely to the right increases the level (to +12dB at 1kHz.) Turning the knob completely to the left decreases the level (to -32dB at 1kHz.)

"Bass" (Input Level Low EQ)

This rotary control adjusts the low-tone sound of the inputs. Turning the knob completely to the right increases the level (to +12dB at 40Hz.) Turning the knob completely to the left decreases the level (to -32dB at 40Hz.)

"PFL" (Input Level Meter and Cue Button)

These meters display the peak levels of the inputs. You can use the "Gain" and EQ controls to match the levels of input signals while Cueing.

For additional information on Cueing, see Section 4 "Cueing Controls."

"Phono/Line Switch" (Input Selector Switch)

These two-position toggles select what input source is engaged among the connected units (see Section 9 "Inputs and Outputs" for details on connecting sources.)

The CH-1 and CH-2 Input Selectors switch between a line level input (typically a CD player) and a Phono Level Input (Turntable.)

These toggles can be rotated to suit your mixing preferences by removing the top Mixer Panel. See Section 10 "Customizing and Servicing your mixer" for details.

Input Level Faders

These slide faders adjust the level for CH-1 and CH-2 respectively.

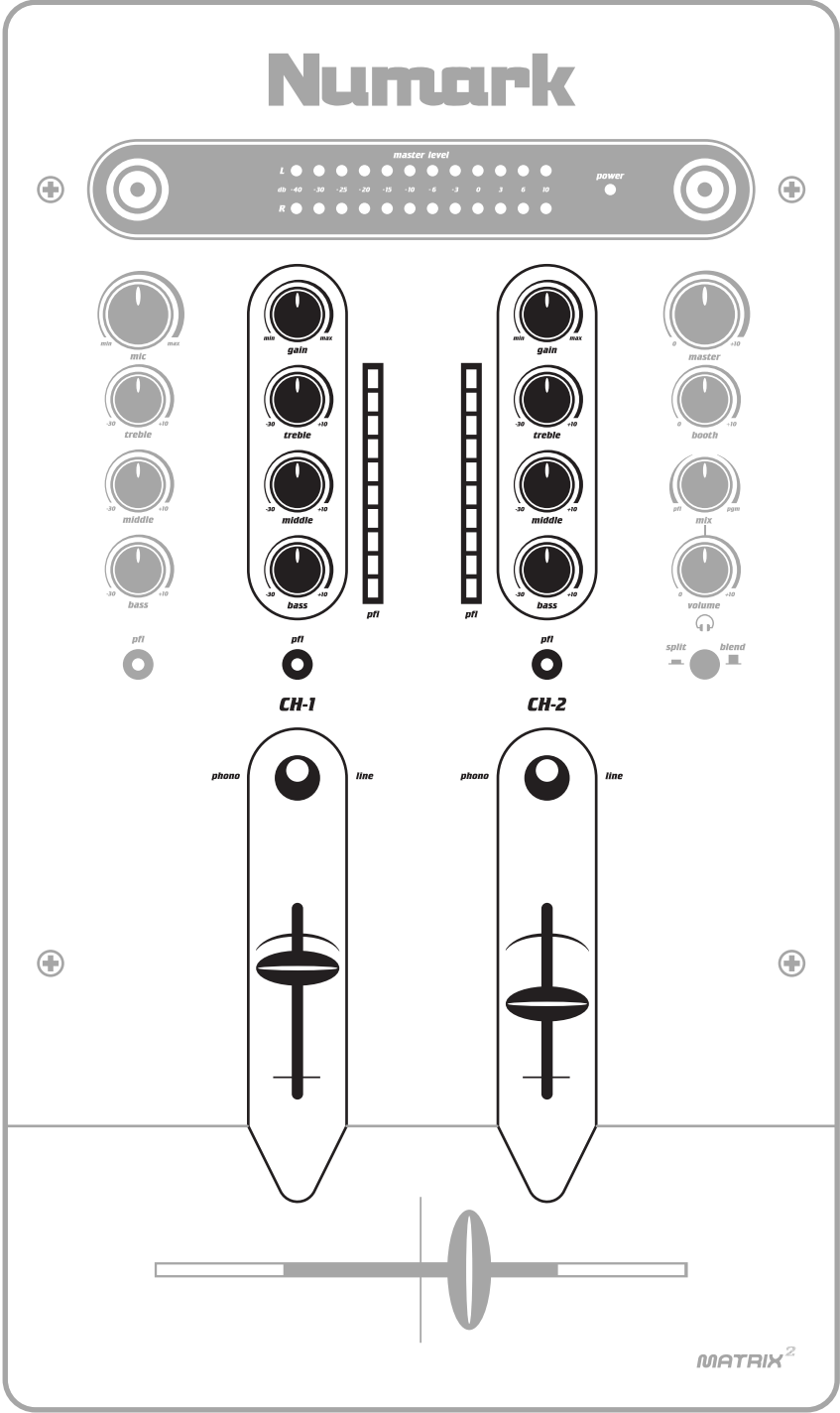

SECTION 2

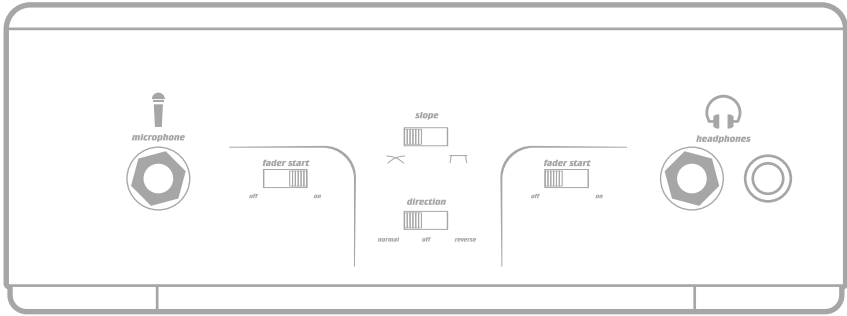

CONTROLS

3. Meters and Lighting

"Master Level" (Master Level Meter)

This meter displays the stereo output levels of the master signal. The display ranges from -40dB to +10dB.

Dual BNC Style Light Connectors

Two BNC style lights can be connected simultaneously to these 12V receptacles.

4. Cueing Controls

"Volume" (Headphone Level)

This rotary control adjusts the levels of the headphones connected to the front panel input. Turning the knob completely to the right increases the level to and turning the knob completely to the left decreases the level.

"Split/Blend" (Master/Split Style Headphone Cueing Switch)

The split cueing mode is engaged by depressing the button into the low position. The split mode means that any selected source (CH-1 to CH-3 and Mic) will be sent to the left channel of the headphones and the program output is sent to the right. If the blend cueing mode is engaged (the button will be in the up position) then the cued or master source (dependent on "Mix") will be heard in both the left and right channels of the headphones.

"Mix" (Master/Cue Blend Control)

This control blends between the cued source(s) and the program output (the program output is the master signal before it reaches the master level control.) At the center position an even mix of both the program output and the cued source are monitored. Turning the knob completely to the right selects only the program output and turning the knob completely to the left monitors only the cued source(s.)

"Headphones" (Quarter Inch and Eighth Inch Headphone Output Terminals)

Two headphones can be connected simultaneously to these Quarter Inch and Eighth Inch output terminals. The Volume should always be set at its lowest setting while connecting and disconnecting headphones to prevent damage to headphones and/or your hearing.

"PFL" (CH-1, CH-2, CH-3 and Mic PFL Buttons)

CH-1, CH-2, CH-3 and the Microphone can be sent to the headphones one at a time or simultaneously for cueing. When depressed, the PFL (cue) button illuminates yellow indicating that the source is being cued. Use the "Mix" control to get a balance of the cued PFL source(s) and the master output in the headphones.

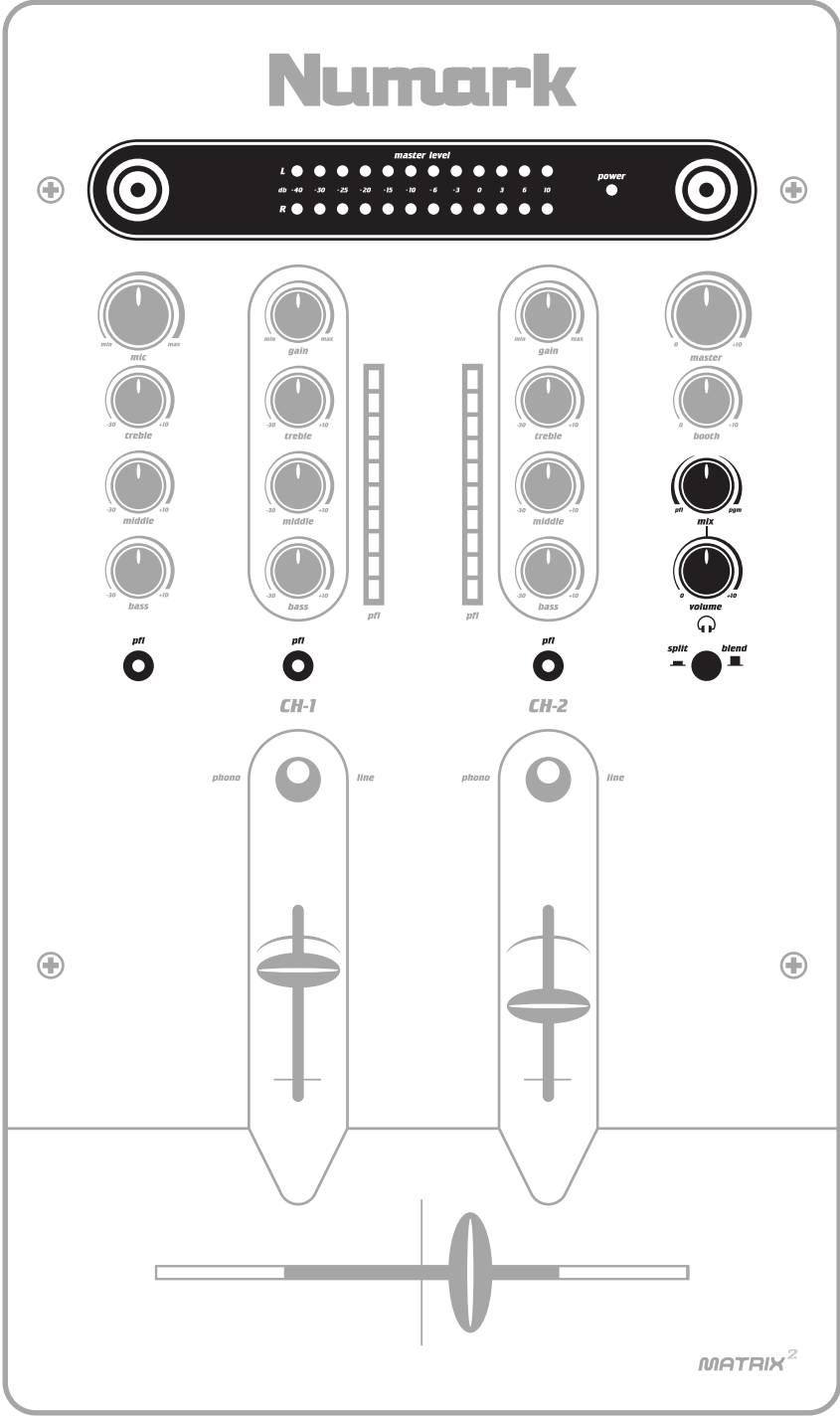

SECTION 3



SECTION 4

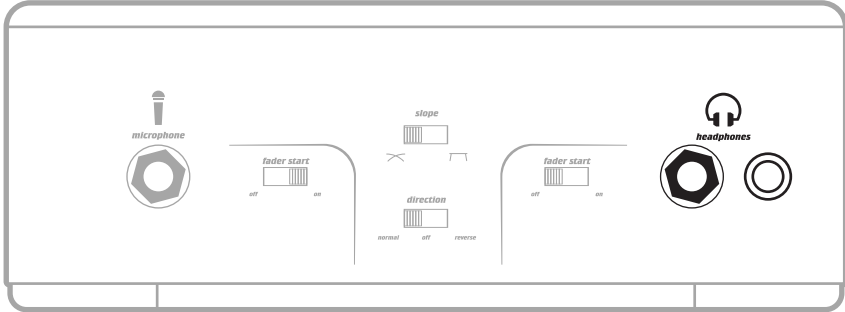

CONTROLS

5. Master Output Controls

"Master" (Main Output Level Control)

This rotary control adjusts the main output levels for any equipment connected to the Master Output on the rear panel (Section 9 "Inputs and Outputs".) Turning the knob completely to the right increases the level to +10dB and turning the knob completely to the left mutes the signal.

"Booth" (Master/Split Style Headphone Cueing Switch)

This rotary control adjusts the auxiliary (AKA booth) output levels for any equipment connected to the Booth Output on the rear panel (Section 9 "Inputs and Outputs".) Turning the knob completely to the right increases the level and turning the knob completely to the left mutes the signal.

Blue Power LED

The blue power LED will illuminate when the mixer has been connected to a power source and switched to the "on" position (See Section 9 "Inputs and Outputs".)

6. Crossfader Controls

Crossfader with Tracking Light System

This slide fader blends between CH-1 and CH-2. Its action can be fine-tuned using the "Slope" control switch or it can be reversed or deactivated by the "Direction" switch. A red light glows on either the right, left or both sides for the Crossfader indicating only the position of the Crossfader, not the amount of signal being sent to the master output.

"Slope" (Crossfader Curve Style Control)

The position of this switch determines where the startup level of CH-1 and CH-2 lie on the crossfader (with respect to "Direction.") When switched to the left, the Crossfader will gradually fade the channel in to the master output signal as it is engaged. When switched to the right, a very sharp fade of the channel will occur immediately when the fader is engaged.

"Direction" (Crossfader Assignment Reverse and Deactivation Control)

The position of this switch can reverse the assignment of CH-1 and CH-2 or deactivate the Crossfader. In the left switch setting ("Normal",) CH-1 is assigned to the left side of the Crossfader and CH-2 is assigned to the right side of the crossfader. In the right switch setting, the assignment of CH-1 and CH-2 are reversed on the Crossfader. In the center position, the Crossfader is deactivated.

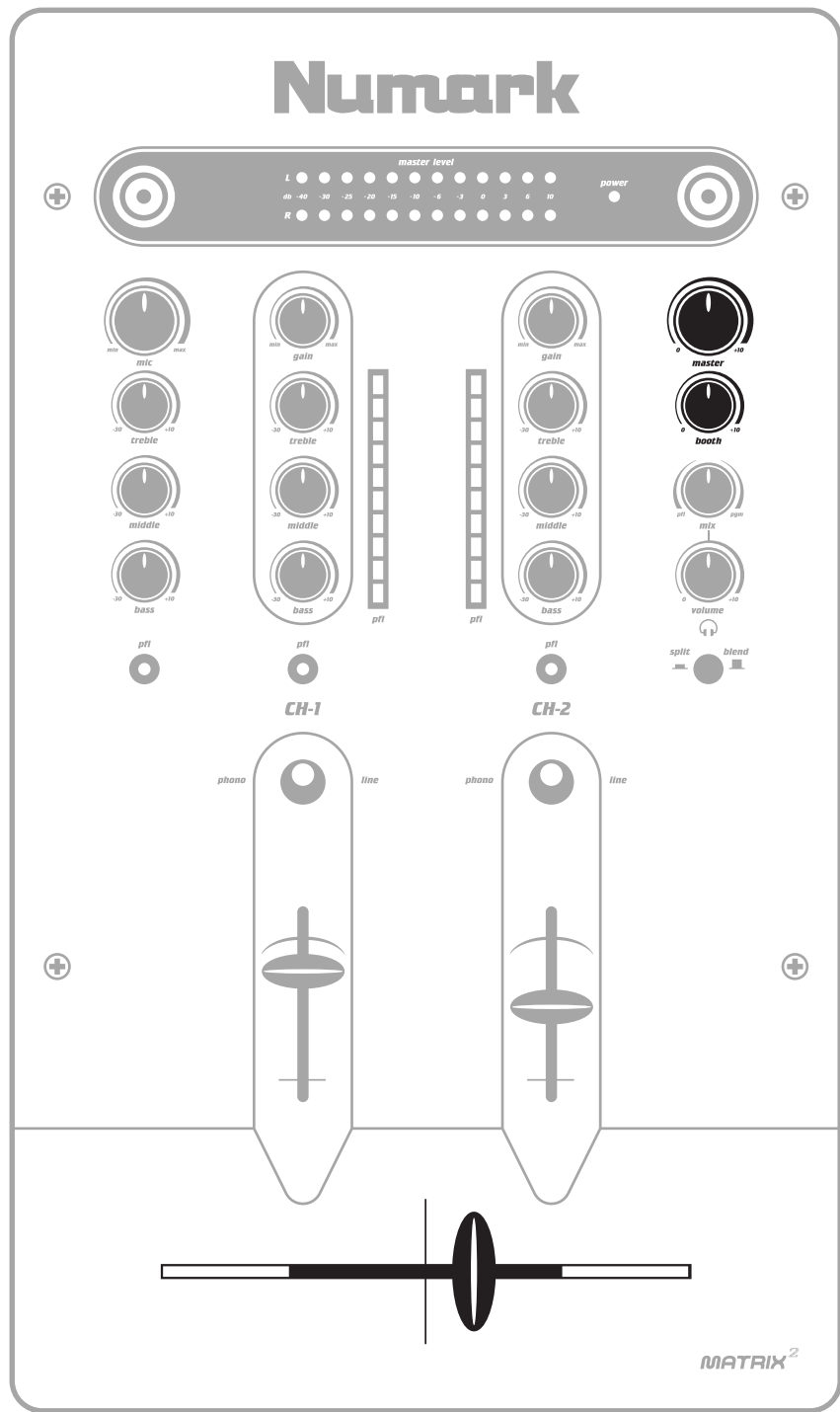

SECTION 5

SECTION 6

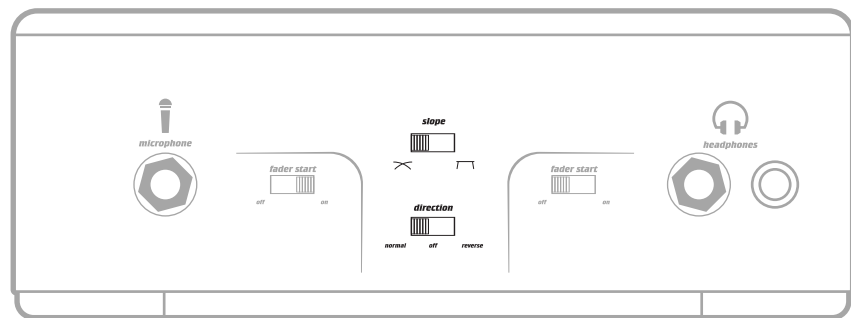

CONTROLS

7. Special Crossfader Related Features

"Fader Start" (Fader Start On/Off switches)

When engaged the fader start can be used to instantly start a fader-start compatible device (See "Inputs and Outputs" Section 9) by moving the Crossfader away from the endpoints. The behavior of this control is largely dependent on the settings of your fader start compatible device.

NOTE: The performance of the fader-start function is also dependent on the settings of the crossfader as described in "Crossfader Controls" Section 6.

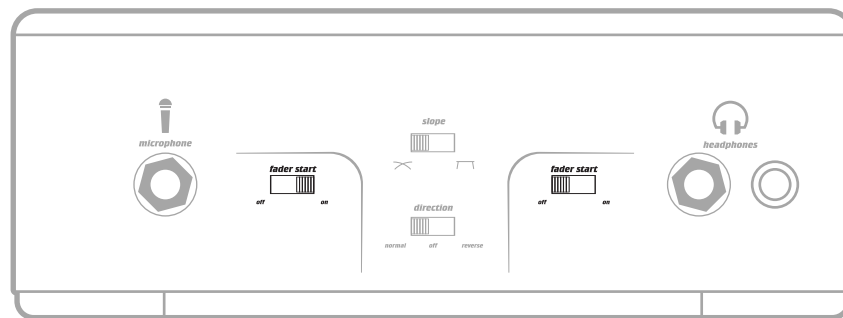
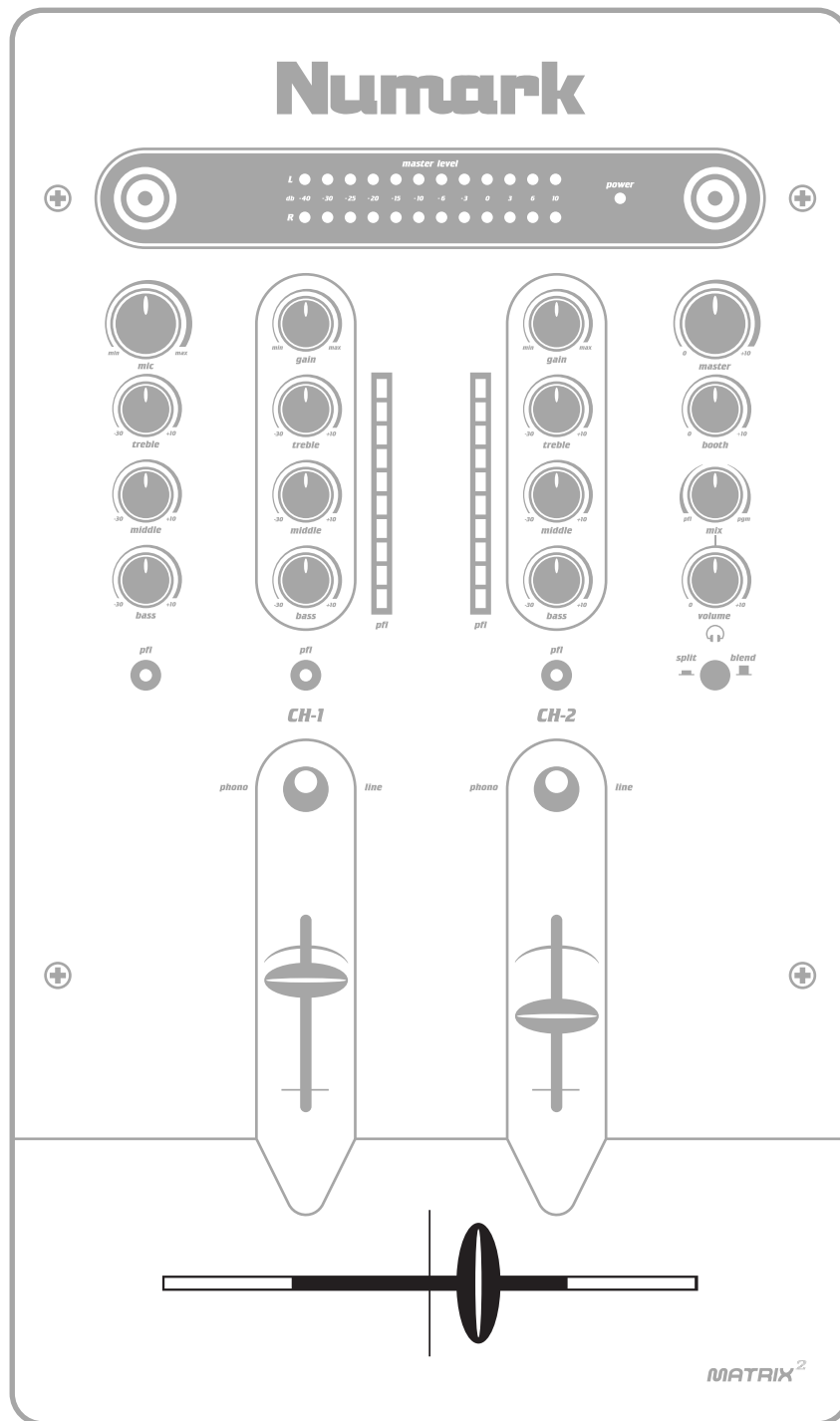

SECTION 7

CONTROLS

9. Inputs and Outputs

CH-1 and CH-2 Phono/Line Stereo Inputs

Each channel has a selectable phono level input (phonograph level/line level) and a line level input. The line level input is used to connect CD players and other line level devices. When connecting a turntable to the phono input, the switch must be set to "PHONO" instead of "AUX." When this switch is set to "AUX", you can connect a line level device to the mixer (CD player, etc.) Please note that many turntables need to be grounded to the mixer with a ground wire to prevent hum and excessive noise (see "GND.") It is also recommended that the mixer be turned off before connecting and disconnecting any sources to the inputs of the mixer.

WARNING: The Input Level Switch on the rear panel of the mixer must be set to "AUX" when connecting line level devices. Failure to do so will result to damage in the mixer.

"Master" (Main Stereo Output)

This RCA output is for connecting an external device such as a PA system, powered monitors or a home stereo. The level of the master stereo output signal increases as the "master" volume control is increased.

"Zone" (Auxiliary Stereo Output)

This RCA output is for connecting a secondary external device such as a booth monitor or second stereo output. The level of the booth output signal will increase as the "Booth" volume control is increased.

"Rec" (Recording Level Stereo Output)

This RCA output is for connecting an external recording device such as a CD Recorder, MD Recorder or a Tape Deck. The level of this signal is not affected by "master" volume or "booth" adjustments but is affected by all other controls.

"GND" (Grounding Lug)

This screw connector should be used to secure any devices connected to the mixer that need to be grounded. Most turntables that are connected to the mixer will need to have a ground wire that is designed to connect to the mixer to eliminate hum and noise.

"Player A/B" (Fader Start Eighth Inch Terminals)

These two eighth inch terminals allow Fader/Remote Start Compatible devices (Numark CD Players) to be connected to the unit using eighth inch fader start cables (not included.) Any connected device can then be remotely started using the Crossfader (Section 7 "Special Crossfader Related Features.") "Fader Start" must be switched to the on position for this feature to work properly.

NOTE: These terminals are only compatible with Digital Pulse Style Reception Devices

AC In and Power Switch

This mixer uses an IEC type power cable. Make sure that the Internal Voltage Selector Switch is properly set before inserting the power cable into the mixer. The mixer should be switched on after all devices are already connected to prevent damage to your equipment. A Blue Power LED indicates that the unit has been switched on (See Section 3 "Meters and Lighting.")

Internal Voltage Selector Switch

This switch allows the voltage for the mixer to be set at 110 VAC or 240 VAC (dependent on region and plugtype.) To switch the voltage setting, remove the top screw on the plastic shield, and rotate the shield counterclockwise.

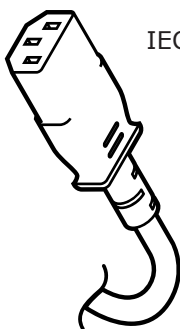
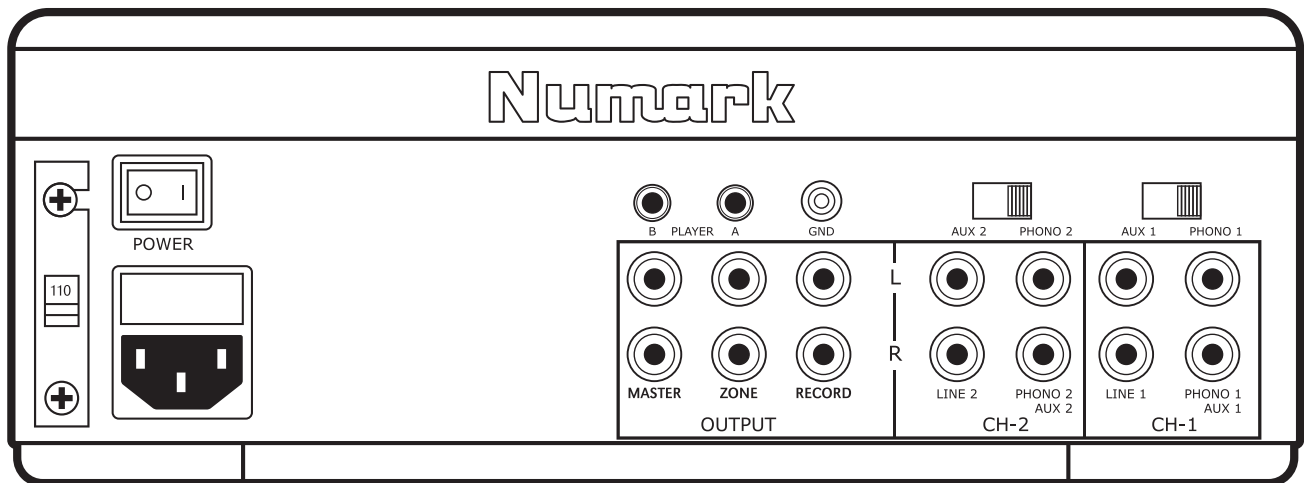

IEC type power cable

CONTROLS

10. Customizing and Servicing Your Mixer



Replacing the Crossfader

This mixer features a replaceable Crossfader. The Crossfader can be removed from the mixer by loosening the two screws at the endpoints of the fader (See illustrations at right.) Follow the steps below for removing the top panel to have access to the Crossfader.

Customizing the Direction of the Input Selector Switches

This mixer features multi directional Input Switches that can be removed and rotated to one of eight positions (See illustrations at right.) Each Input Selector Switch is secured to the mixer by two adjacent screws. Be sure to make note of the current switch position and the new switch positions before rotating the switches to prevent any uncertainty before re-securing the top panel. Follow the steps below for removing the top panel to have access to the Input Selector Switches.

Removing the Top Panel

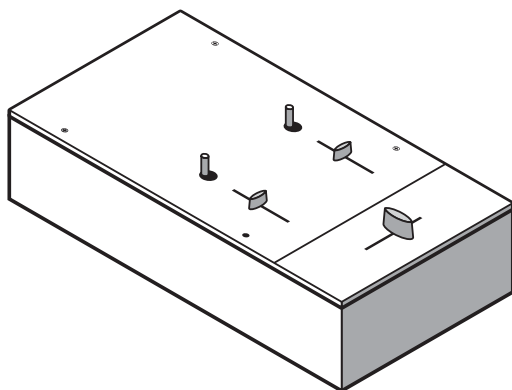

1. Unplug the mixer and set it on a flat surface.

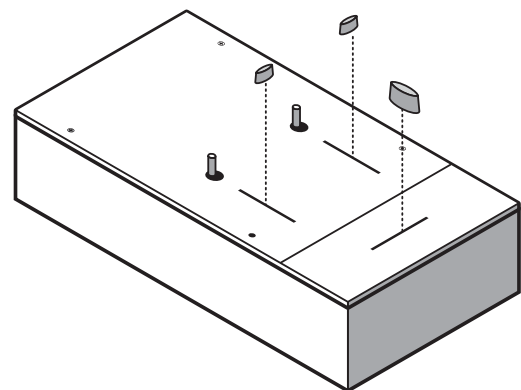

2. Remove the Three Fader Knobs.

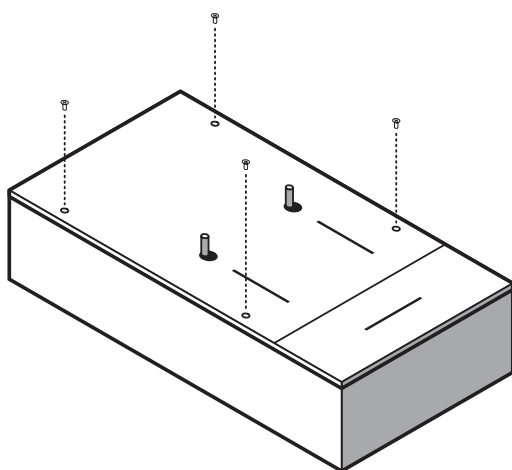

3. Remove the four screws that secure the top panel using a #2 Philips Screwdriver.

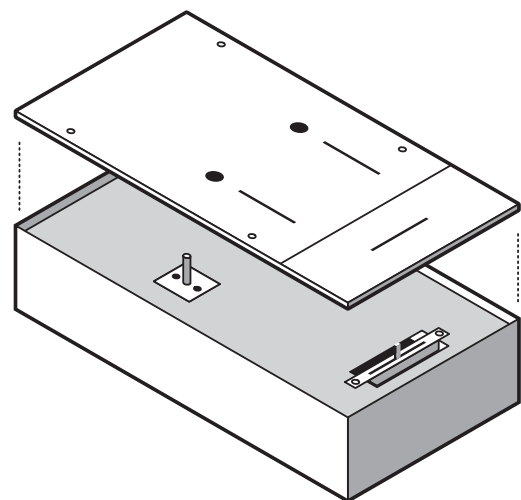

4. Carefully remove the top panel.

Replacing the Crossfader

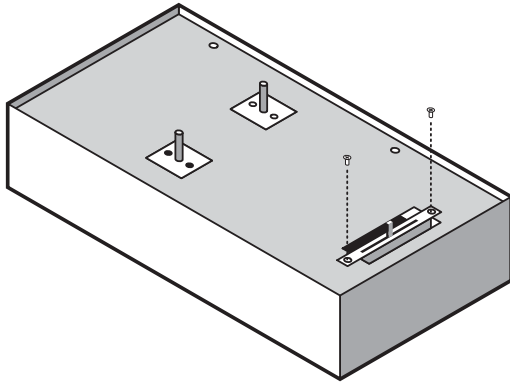

1. After removing the top panel, remove the two screws that secure the crossfader using a #2 Philips Screwdriver.

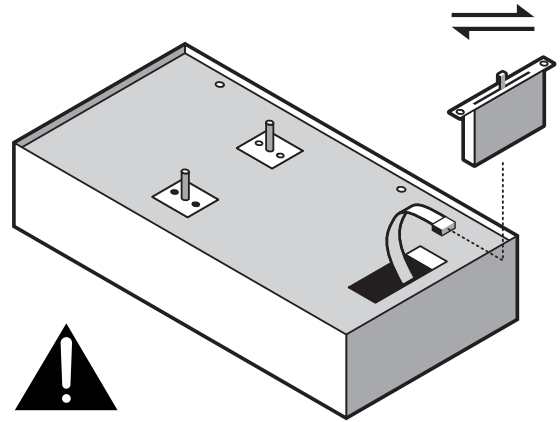

2. Carefully slide the crossfader out of the mixer chassis, and unplug the harness from the bottom of the part. Replace the crossfader, refasten the two screws that hold the crossfader in place.
3. Resecure the top panel, test the function, and refasten the four screws that secure the top panel.

Customizing the Direction of the Input Selector Switches

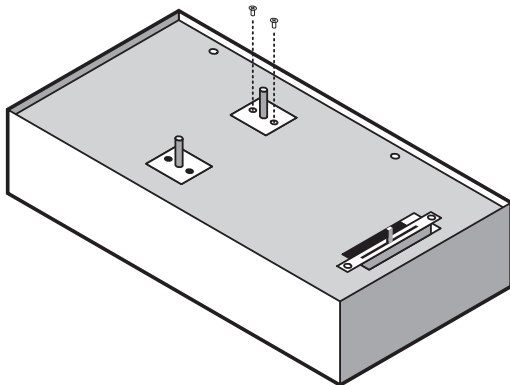

1. After removing the top panel, remove the two screws that secure the selector switch you want to rotate using a #2 Philips Screwdriver.

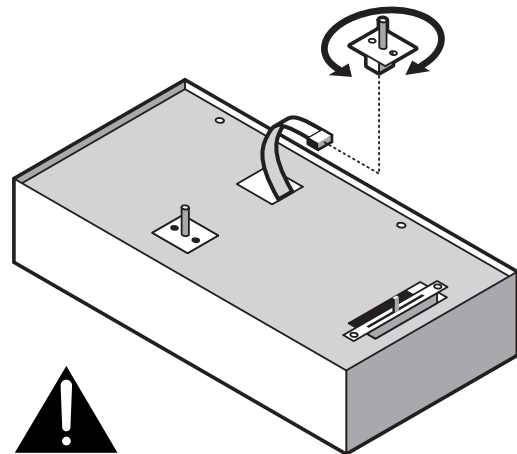

2. Carefully slide the switch out of the mixer chassis, and unplug the harness from the bottom of the part. Rotate and replace the switch, refasten the two screws that hold the switches in place.
3. Resecure the top panel, test the function, and refasten the four screws that secure the top panel.

SPECIFICATIONS

Inputs:

Line: 10K ohm input impedance
63mV rms sensitivity for 1.22V output

Mic: 600 ohm input impedance unbalanced
1.5mV rms sensitivity for 1.22V output
180mV rms max input

Phono: 47Kohm input impedance
1mV rms sensitivity @ 1KHz for 1.22V output

Outputs:

Line: 9V rms max
Headphone: 0.5W into 47ohm

Distortion: less than 0.01%

Signal to Noise Ratio: (maximum output) JIS-A weighted

Line: Better than 92dB
Mic: Better than 82dB
Phono: Better than 85dB

Frequency response:

Line: 20Hz-20KHz +/-0.5dB
Mic: 20Hz-15KHz +/-0.5dB
Phono: +/-1dB except for controlled attenuation of -3dB
@ 20Hz to reduce rumble and feedback

Channel equalizer:

Bass: +12/-32dB @40Hz
Middle: +12/-32dB @1KHz
Treble: +10/-28dB @15KHz

Power consumption:

11.5 Watt typical
14.2 Watt with full headphone output

Dimensions:

220mm(W) by 370mm(D) by 90mm(H)

Weight: 4.2 kgs

LIMITED PRODUCT WARRANTY

1. What is covered and for how long? NUMARK INDUSTRIES LCC ("NUMARK") warrants to the original purchaser that NUMARK'S mixers are free from defects in material and workmanship under normal use and service for the period commencing upon the date of purchase from an authorized NUMARK dealer and continuing for the following period of time after that date:

2 Years

3 Years with the completion of the warranty card provided that the warranty card is completed and returned within 30 days from the date of purchase.

2. What is not covered? This Limited Warranty is conditioned upon proper use of the product by the purchaser. This Limited Warranty does not cover:

- (a) Damage caused by improper installation or improper connection to any peripheral
- (b) Damage caused by an external electrical fault
- (c) Damage from use of parts not manufactured or sold by Numark
- (d) Product purchased from anyone other than a Numark authorized dealer
- (e) Modifications to product not approved in writing by Numark
- (f) Equipment that has the serial number removed or made illegible
- (g) Normal cosmetic and mechanical wear
- (h) Damage or loss during transit to an Authorized Numark Repair Center
- (i) Crossfaders

3. What are NUMARK'S obligations? During the applicable warranty period, NUMARK will repair or replace, at NUMARK'S sole option, without charge to the purchaser, any defective component part of the mixer. To obtain service under this Limited Warranty, purchaser must first contact NUMARK and obtain a return authorization number ("RA#"). Purchaser must then return the mixer to NUMARK in an adequate container for shipping, accompanied by purchaser's sales receipt or comparable proof of sale showing the date of purchase, the serial number of the product, and the seller's name and address. To obtain an RA# and assistance on where to return the mixer, contact NUMARK customer service at 401-295-9000. Upon receipt, NUMARK will repair or replace the defective products. NUMARK may, at NUMARK'S sole option, use rebuilt, reconditioned, or new parts or components when repairing any product or replace a product with a rebuilt, reconditioned or new product. Repaired mixers will be warranted for a period equal to the remainder of the original Limited Warranty on the original mixer or for 90 days, whichever is longer. All replaced parts, components, boards and equipment become the property of NUMARK. If NUMARK determines that any mixer is not covered by this Limited Warranty, purchaser must pay all parts, shipping, and labor charges for the repair or return of such mixer.

4. What are the limits on NUMARK'S liabilities? THE WARRANTIES GIVEN IN THIS LIMITED WARRANTY, TOGETHER WITH ANY IMPLIED WARRANTIES COVERING NUMARK MIXERS, INCLUDING WITHOUT LIMITATION ANY WARRANTIES OF MERCHANTABILITY OR FITNESS FOR A PARTICULAR PURPOSE, ARE LIMITED TO THE DURATION OF THIS LIMITED WARRANTY. EXCEPT TO THE EXTENT PROHIBITED BY APPLICABLE LAW, NUMARK SHALL NOT BE LIABLE FOR ANY SPECIAL, INCIDENTAL, CONSEQUENTIAL, INDIRECT OR SIMILAR DAMAGES, LOSS OF PROFITS, DAMAGES TO PURCHASER'S PROPERTY, OR INJURY TO PURCHASER OR OTHERS ARISING OUT OF THE USE, MISUSE OR INABILITY TO USE ANY NUMARK MIXER, BREACH OF WARRANTY, OR NEGLIGENCE, INCLUDING BUT NOT LIMITED TO NUMARK'S OWN NEGLIGENCE, EVEN IF NUMARK OR ITS AGENT HAS BEEN ADVISED OF SUCH DAMAGES, OR FOR ANY CLAIM BROUGHT AGAINST PURCHASER BY ANY OTHER PARTY. THIS LIMITED WARRANTY IS THE COMPLETE WARRANTY FOR NUMARK'S MIXERS, AND IS GIVEN IN LIEU OF ALL OTHER EXPRESS WARRANTIES. THIS LIMITED WARRANTY SHALL NOT EXTEND TO ANYONE OTHER THAN THE ORIGINAL PURCHASER OF THIS PRODUCT AND STATES PURCHASER'S EXCLUSIVE REMEDY. IF ANY PORTION OF THIS LIMITED WARRANTY IS ILLEGAL OR UNENFORCEABLE BY REASON OF ANY LAW, SUCH PARTIAL ILLEGALITY OR UNENFORCEABILITY SHALL NOT AFFECT THE ENFORCEABILITY OF THE REMAINDER OF THIS LIMITED WARRANTY WHICH PURCHASER ACKNOWLEDGES IS AND WILL ALWAYS BE CONSTRUED TO BE LIMITED BY ITS TERMS OR AS LIMITED AS THE LAW PERMITS.

This Limited Warranty allocates risk of product failure between purchaser and NUMARK, and NUMARK'S product pricing reflects this allocation of risk and the limitations of liability contained in this Limited Warranty. The agents, employees, distributors, and dealers of NUMARK are not authorized to make modifications to this Limited Warranty, or make additional warranties binding on NUMARK. Accordingly, additional statements such as dealer advertising or presentation, whether oral or written, do not constitute warranties by NUMARK and should not be relied upon.

5. How does state law apply to this warranty? SOME STATES DO NOT ALLOW THE EXCLUSION OR LIMITATIONS OF INCIDENTAL OR CONSEQUENTIAL DAMAGES OR HOW LONG AN IMPLIED WARRANTY LASTS, SO THE ABOVE LIMITATIONS OR EXCLUSIONS MAY NOT APPLY TO PURCHASER.

This Limited Warranty gives you specific legal rights. You may also have other rights, which vary from one jurisdiction to another.

RETURN INFORMATION (US ONLY)

- a) A Return Authorization number must be obtained from Numark through the address or phone numbers below.
- b) A copy of the original sales receipt must also be included for the equipment to be repaired under warranty.
- c) The faulty equipment must be packed in its original packaging.
- d) One additional outer layer of packaging must be included to ensure product safety. Failure to do so may inadequately protect the equipment in transit and, therefore, jeopardize the customer's warranty.
- e) Numark will not accept COD shipments and no call tags will be issued for merchandise return.
- f) Numark will not return repaired merchandise to customers by priority service, unless by written request at the customer's cost. Requests must be submitted in writing with merchandise returned.
- g) The defective Numark equipment should be sent, FREIGHT PREPAID with Return Authorization number clearly printed on the outer packaging and original sales receipt enclosed to:

NUMARK INDUSTRIES
Attention: Service Department
11 Helmsman Avenue
North Kingstown, RI 02852 USA
Phone: 1 (401) 295-9000
Fax: 1 (401) 295-5200
Web: www.numark.com

TROUBLESHOOTING

Problem	Cause?	Solution
Mixer does not turn on.	Disconnected Power Cord?	Connect Power Cord. See INPUTS AND OUTPUTS, pages 15-16
The sound level is very low.	<p>The Input Selector Switch is in the wrong position.</p> <p>The component is connected to the wrong input terminal or channel.</p> <p>The main output device is connected to the Recording Level Output.</p>	<p>Select the device that is playing with the input selector switch. See CONTROLS, page 7</p> <p>Connect the input to the correct channel using the Set-Up Diagram. See SETUP DIAGRAM, page 4</p> <p>Connect the output device to the Master Output. See INPUTS AND OUTPUTS, pages 15-16</p>
The output sound is very distorted.	<p>The Input Trims are set too high.</p> <p>The Master Volume is set too high.</p>	<p>Adjust the Input Trims so that they average 0db on the LED display. See CONTROLS, page 7</p> <p>Adjust the Master Volume so that 0db is averaged on the LED display. See CONTROLS, page 11</p>
The Crossfader does not work.	The Crossfader Reverse Toggle is in the wrong position.	Set the Crossfader Reverse Toggle to the opposite direction. See CONTROLS, page 13
The Output sound exhibits excessive hum or buzzing.	The Turntable Grounding wires are not connected.	Connect the Turntable Ground wires to their respective Grounding Lug. See SETUP DIAGRAM, page 4 See INPUTS AND OUTPUTS, pages 15-16

NOTE:

Static electricity and/or other external interference may cause this unit to malfunction. To reset the unit to its normal condition, turn the power off and then on again. If the problem continues to persist, refer to the connected component's troubleshooting guides. If the problem is not resolved after checking these items, contact the nearest authorized Numark dealer.